



AP5010B Antenna Positioner

- M1

Features

The Model AP5010B Antenna positioner is a heavy-duty non-conductive support and positioner for the AR RF/Microwave Instrumentation ATR26M6G, ATR26M6G-1, ATR26M1G or ATR26M250 high-gain log-periodic antennas. Includes locking casters, with leveling feet, for easy movement in a shielded room or open site testing, the AP5010B allows the test engineer to position the antenna for either vertical or horizontal polarization as well as permitting the antenna to be tilted 30 degrees. The height adjustment is from 2.07 meters to 3.31 meters, measured from the floor to the centerline of antenna. The base leg adjustment is from 1.53 meters overall to 2.04 meters. The primary structure of the AP5010B is constructed of Fiberglass, PVC, Delrin, and Nylatron and the weight of the unit without an antenna is approximately 45 kg (98 lbs). The AP5010B is equipped with 4" neoprene swivel casters with brakes. The AP5010BM1 is equipped with 6" heavy duty semi-pneumatic swivel casters with brakes. Optional mast extensions are available for custom applications.

The export classification for this equipment is EAR99. These commodities, technology or software are controlled for export in accordance with the U.S. Export Administration Regulations. Diversion contrary to U.S. law is prohibited.

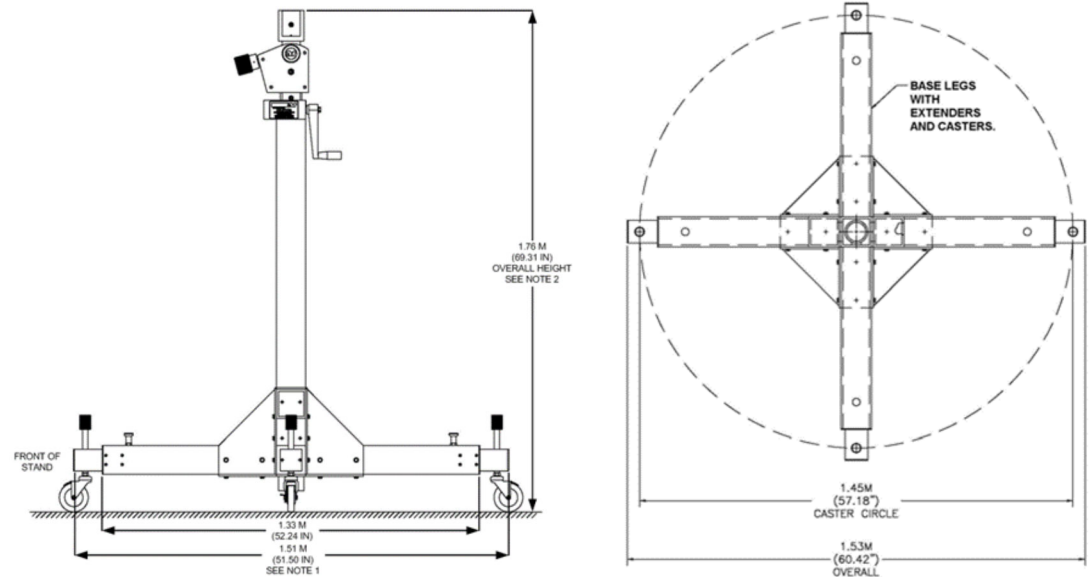

AR RF/Microwave
Instrumentation
160 Schoolhouse Rd
Souderton, PA 18964
215-723-8181

For an applications engineer call: 800.933.8181

www.arworld.us



AP5010B

Antenna Positioner

- M1

Specifications

Page 2

LOAD CAPACITY: 45.36 kg (100 lbs)

MAXIMUM HEIGHT (to centerline of antenna): 3.31 m (130.25 in)

MINIMUM HEIGHT (to centerline of antenna): 2.07 m (81.69 in)

BASE LEG: 1.53 m (60.42 in); extends to 2.04 m (80.19 in)

TILT ANGLE: 0–30°

MATERIAL: Fiberglass, PVC, Delrin, Nylatron

WEIGHT (approximate): 45 kg (98 lbs)

EXPORT CLASSIFICATION: EAR99

ACCESSORIES:

10050337 48" Mast Extension kit

10050338 72" Mast Extension kit

NOTE 1: Legs must be in the fully extended position prior to and during all times the antenna is mounted on the stand.

NOTE 2: When moving the antenna stand to a different location, the mast must be lowered to the minimum height.

NOTE3: AP5010BM1 casters add 2.5 inches to the height.